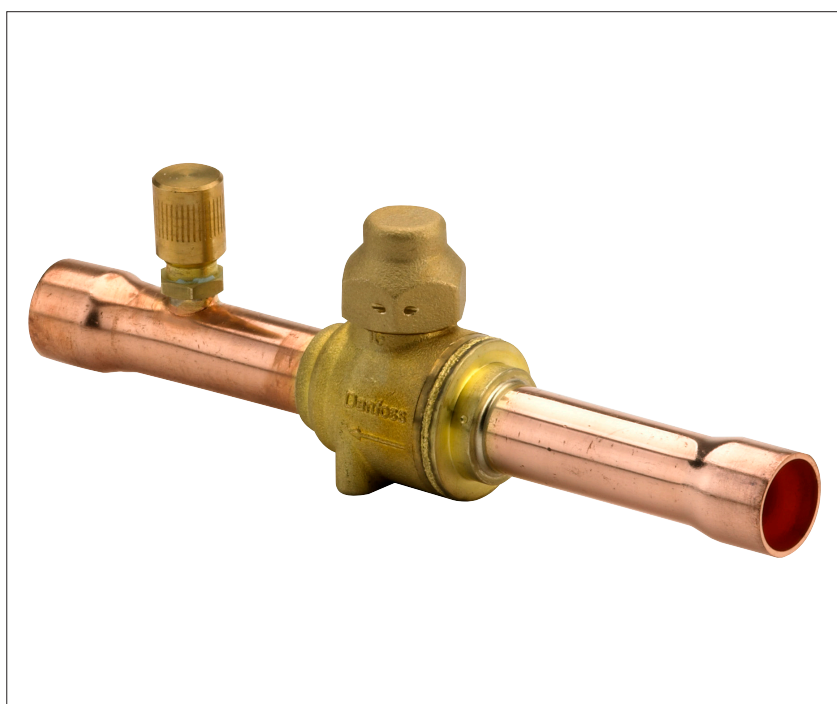

Data sheet

Shut-off ball valve

Type GBC for R744 / CO₂ (45 bar / 650 psi) Version 2

Danfoss shut-off ball valves, type GBC for CO₂ are manually operated shut-off valves only for single-flow direction.

The valves are approved for applications in liquid, suction and hot-gas lines in refrigeration and airconditioning systems.

The valves offer maximum tightness across the seat/seal with minimum pressure drop.

These ball valves give maximum flow in the fully open position. They are designed for operation within a broad temperature range.

The valves are equipped with a one-piece seal cap to prevent tampering.

Features

- Slimline body – easier to install and service
- ¼ turn from fully open to fully closed
- Rotation stops at fully open and fully closed positions
- Indicator on spindle top shows degree of opening
- Precision laser welded construction
- Double O-ring stem seal design
- Burst-proof spindle design
- Valve seal of low friction, tight-sealing modified PTFE Teflon®
- Drilled and tapped for panel mounting
- Relief hole design to release entrapped liquid
- Selected O-ring material for CO₂ refrigerant
- Customized brass material ensures consistent performance under aggressive environment

Approvals

Technical data

Refrigerants	R 744 (CO ₂)
Media temperature range	-40 °C – 100 °C / -40 °F – 212 °F
Max. working pressure (PS / MWP)	45 bar / 650 psig
Flow direction	single-flow

Notes: For the application use with R744 as part of a secondary loop or cascade:

1. The design pressure of the refrigerant containing component is not less than the design pressure of the associated components.
2. The component is not provided with any pressure relief or pressure regulating relief valve and that a sufficient number of valves having capacity deemed adequate shall be field-installed on the refrigeration system.
3. When the refrigeration system is de-energized, venting of R744 may occur through the pressure regulating relief valves, and may need to be recharged, but the valve should not be defeated or bypassed.
4. A sufficient number of pressure relief and pressure regulating valves may need to be provided based upon system capacity and located such that no stop valve is provided between the relief valve and the parts or section of the system being protected.

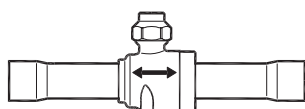
Ordering

GBC without access port, ODF / ODF

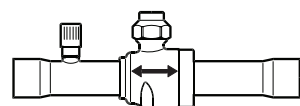
Type	Solder ODF / ODF connection		K _v value ¹⁾ [m ³ /h]	C _v value ¹⁾ [gal/min]	Code no.
	[inch]	[mm]			
GBC 6s	1/4	–	1.74	2.01	009L7520
	–	6	1.74	2.01	009L7570
GBC 10s	3/8	–	7.52	8.69	009L7521
	–	10	7.52	8.69	009L7571
GBC 12s	1/2	–	12.92	14.94	009L7522
	–	12	12.92	14.94	009L7572
GBC 16s	5/8	16	15.66	18.10	009L7523
GBC 18s	3/4	–	21.93	25.35	009L7524
	–	18	21.93	25.35	009L7574
GBC 22s	7/8	22	33.34	38.54	009L7525
GBC 28s	1 1/8	–	62.25	71.96	009L7526
	–	28	62.25	71.96	009L7576
GBC 35s	1 3/8	35	92.76	107.23	009L7528
GBC 42s	1 5/8	–	134.76	155.78	009L7529
	–	42	134.76	155.78	009L7579

¹⁾ calculated based on fluid dynamic equations

GBC with access port, ODF / ODF

Type	Solder ODF / ODF connection		K _v value ¹⁾ [m ³ /h]	C _v value ¹⁾ [gal/min]	Code no.
	[inch]	[mm]			
GBC 6s	1/4	–	1.74	2.01	009L7553
	–	6	1.74	2.01	009L7554
GBC 10s	3/8	–	7.52	8.69	009L7555
	–	10	7.52	8.69	009L7556
GBC 12s	1/2	–	12.92	14.94	009L7557
	–	12	12.92	14.94	009L7558
GBC 16s	5/8	16	15.66	18.10	009L7534
GBC 18s	3/4	–	21.93	25.35	009L7563
	–	18	21.93	25.35	009L7564
GBC 22s	7/8	22	33.34	38.54	009L7536
GBC 28s	1 1/8	–	62.25	71.96	009L7565
	–	28	62.25	71.96	009L7566
GBC 35s	1 3/8	35	92.76	107.23	009L7567
GBC 42s	1 5/8	–	134.76	155.78	009L7568
	–	42	134.76	155.78	009L7569

¹⁾ calculated based on fluid dynamic equations

Data sheet | Shut-off ball valve for R744 CO₂ Version 2

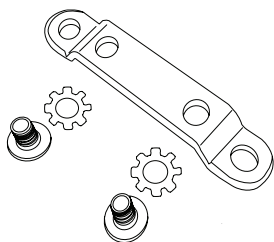
Spare parts



Bracket kit

Type	Valve connection size		Industrial pack [pcs.]	Code no.
	[inch]	[mm]		
GBC 6s - GBC 16s	$\frac{1}{4} - \frac{5}{8}$	6 - 16	12	009G7084
GBC 18s - GBC 22s	$\frac{3}{4} - \frac{7}{8}$	18 - 22	12	009G7085
GBC 28s	$1 \frac{1}{8}$	28	10	009G7086
GBC 35s	$1 \frac{3}{8}$	35	5	009G7087
GBC 42s	$1 \frac{5}{8}$	42	4	009G7088



Seal cap kit

Type	Valve connection size		Industrial pack [pcs.]	Code no.
	[inch]	[mm]		
GBC 6s - GBC 22s	$\frac{1}{4} - \frac{7}{8}$	6 - 22	6	009L7210
GBC 28s - GBC 35s	$1 \frac{1}{8} - 1 \frac{3}{8}$	28 - 35	4	009L7211
GBC 42s	$1 \frac{5}{8}$	42	4	009L7212

Design / Function

1. Connection
2. Valve body
(with single directional arrow)
3. Ball seat (modified PTFE)
4. Valve tail
5. Stainless steel ball
6. Double spindle O-ring seal
(chloroprene)
7. Cap seal (PTFE)
8. Seal cap
9. Spindle
10. Pin
11. Guide ring
12. Schrader valve
13. Relief hole

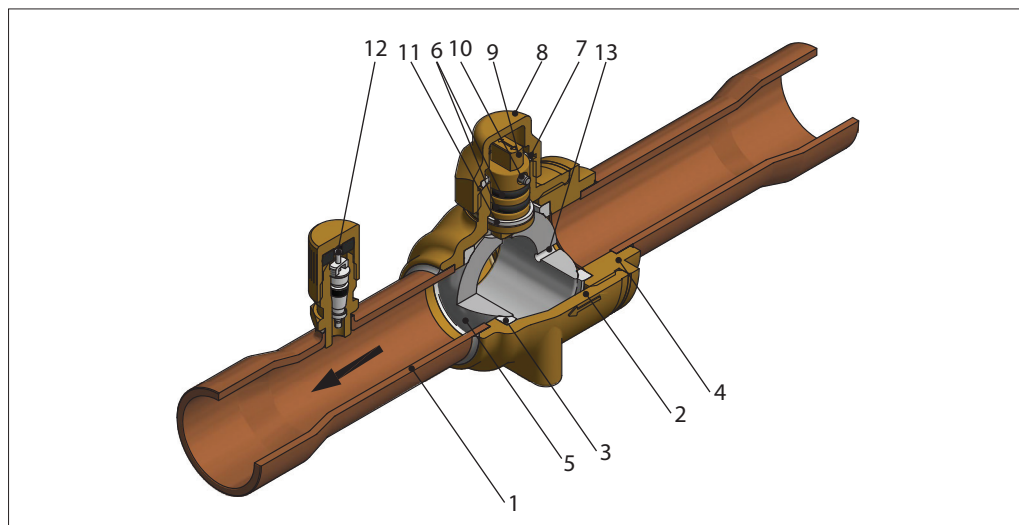

Direct flow gives maximum through-flow with minimum pressure drop across valve. The combination of laser-welded valve body (2) and valve tail (4), ball seat/seal (3), double spindle O-ring seal (6), and cap seal (7) gives absolutely minimum leakage.

Dimensions and weights

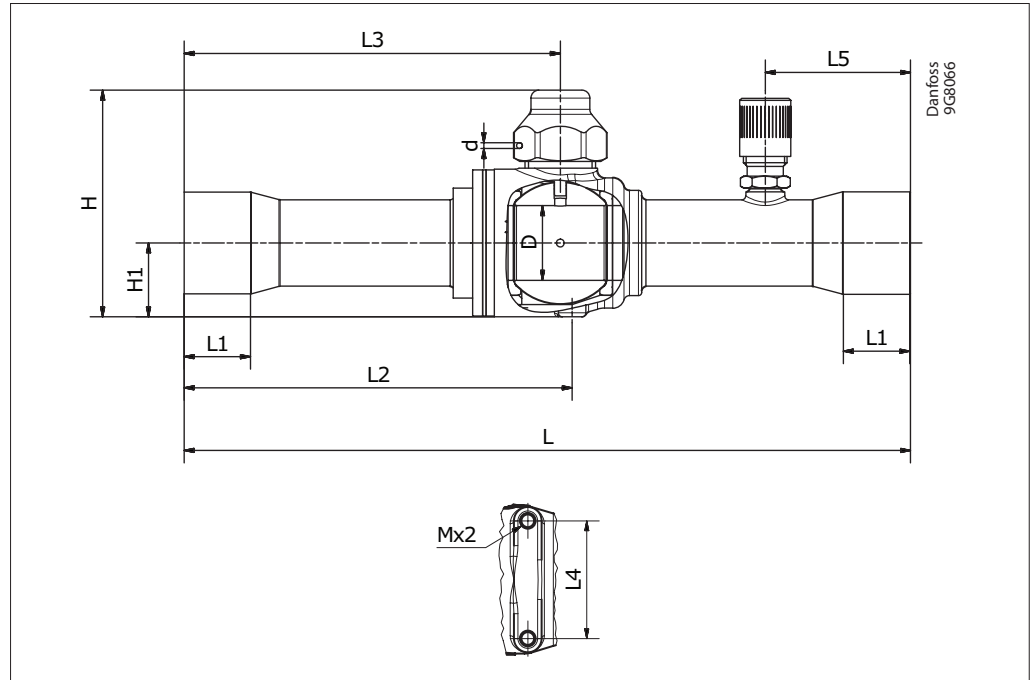

SI units

Type	Connection		H	H1	L	L1	L2	L3	L4	L5	M	D	d	Weight
	[inch]	[mm]	[mm]	[mm]	[mm]	[mm]	[mm]	[mm]	[mm]	[mm]	[mm]	[mm]	[mm]	[Kg] ¹⁾
GBC 6s	1/4	6	50	15	139	7	75	73	22	31	M4 × 0.7	14.0	1.5	0.2
GBC 10s	3/8	—	50	15	139	8	75	73	22	31	M4 × 0.7	14.0	1.5	0.2
GBC 10s	—	10	50	15	139	9	75	73	22	31	M4 × 0.7	14.0	1.5	0.2
GBC 12s	1/2	12	50	15	161	10	86	84	22	31	M4 × 0.7	14.0	1.5	0.2
GBC 16s	5/8	16	50	15	161	12	86	84	22	31	M4 × 0.7	14.0	1.5	0.2
GBC 18s	3/4	18	58	19	185	14	99	96	30	37	M4 × 0.7	19.0	1.5	0.4
GBC 22s	7/8	22	58	19	185	17	99	96	30	37	M4 × 0.7	19.0	1.5	0.4
GBC 28s	1 1/8	28	80	25	208	20	112	108	38	44	M4 × 0.7	25.5	1.5	0.9
GBC 35s	1 3/8	35	89	30	251	25	136	130	48	44	M6 × 1.0	32.0	1.5	1.4
GBC 42s	1 5/8	42	110	35	281	29	151	145	55	56	M6 × 1.0	38.0	1.5	2.2

¹⁾ Calculated value

US units

Type	Connection		H	H1	L	L1	L2	L3	L4	L5	M	D	d	Weight
	[inch]	[mm]	[inch]	[inch]	[inch]	[inch]	[inch]	[inch]	[inch]	[inch]	[mm]	[inch]	[inch]	[lbs] ¹⁾
GBC 6s	1/4	6	2.0	0.6	5.5	0.3	3.0	2.9	0.9	1.2	M4 × 0.7	0.6	0.1	0.5
GBC 10s	3/8	—	2.0	0.6	5.5	0.3	3.0	2.9	0.9	1.2	M4 × 0.7	0.6	0.1	0.5
GBC 10s	—	10	2.0	0.6	5.5	0.4	3.0	2.9	0.9	1.2	M4 × 0.7	0.6	0.1	0.5
GBC 12s	1/2	12	2.0	0.6	6.3	0.4	3.4	3.3	0.9	1.2	M4 × 0.7	0.6	0.1	0.5
GBC 16s	5/8	16	2.0	0.6	6.3	0.5	3.4	3.3	0.9	1.2	M4 × 0.7	0.6	0.1	0.5
GBC 18s	3/4	18	2.3	0.7	7.3	0.6	3.9	3.8	1.2	1.5	M4 × 0.7	0.7	0.1	1.0
GBC 22s	7/8	22	2.3	0.7	7.3	0.7	3.9	3.8	1.2	1.5	M4 × 0.7	0.7	0.1	1.0
GBC 28s	1 1/8	28	3.1	1.0	8.2	0.8	4.4	4.3	1.5	1.7	M4 × 0.7	1.0	0.1	2.0
GBC 35s	1 3/8	35	3.5	1.2	9.9	1.0	5.4	5.1	1.9	1.7	M6 × 1.0	1.3	0.1	3.1
GBC 42s	1 5/8	42	4.3	1.4	11.1	1.1	5.9	5.7	2.2	2.2	M6 × 1.0	1.5	0.1	4.9

¹⁾ Calculated value